

**DENSE FLOW CHARGING CHUTE -
INSIDE CYLINDER**

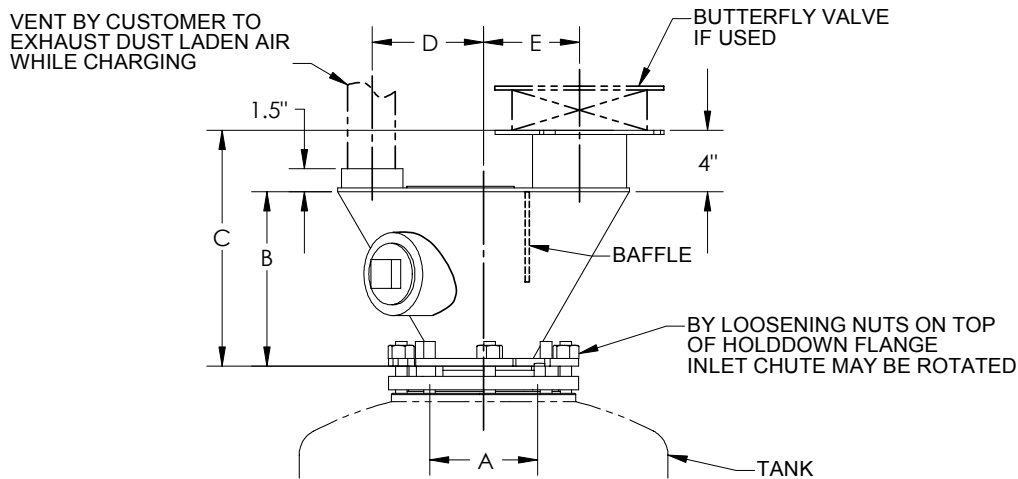
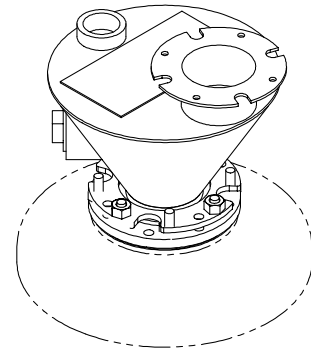
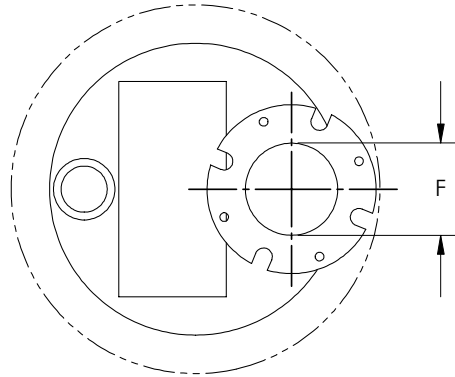

OPENING DIA. A	B	C	D	E	F	PART #
6"	12"	16"	6 1/2"	6 1/4"	6"	DF38204
10"	12"	16"	8 1/2"	7 1/4"	8"	DF38205

THE DENSE FLOW CHARGING CHUTE is used to direct material from the supply point to the charge opening of the Pump Vessel. The baffle inside the chute reduces the head pressure of material against the closing gate. It also has a vent connection to vent displaced air from the Pump Vessel to a dust collector. This feature eliminates the need of a vent valve on the Pump Vessel and therefore reduces maintenance on the system. The above chute is normally used with an inside closing cylinder.

NOTE: Specifications and dimensions subject to change.