

DENSE FLOW BAG DUMP HOPPER

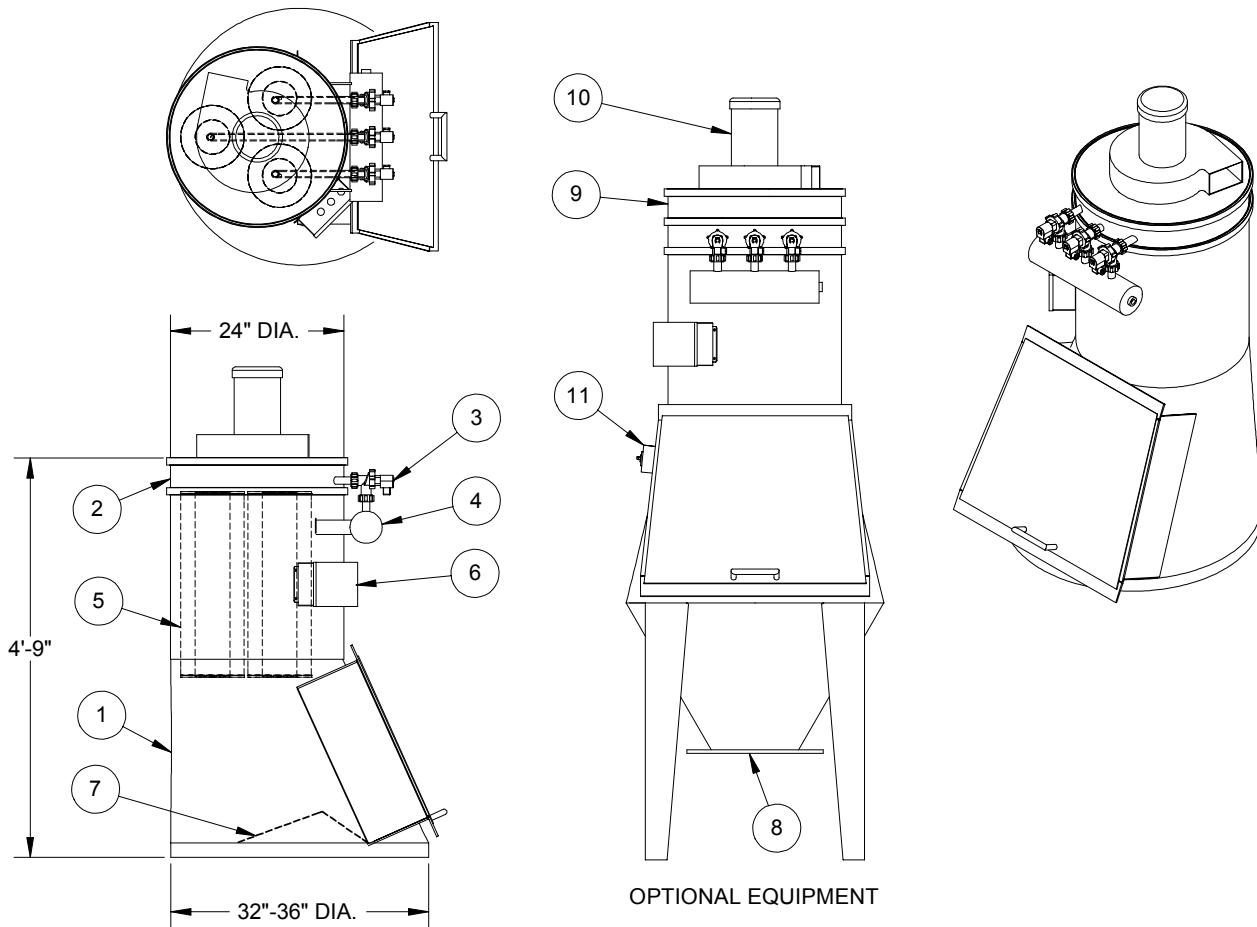

ITEM	DESCRIPTION
1	Housing 12 GA.
2	Removable Clean Air Plenum
3	Diaphragm Valve with Solenoid
4	Compressed Air Header
5	Filter Cartridges
6	Timer Control Panel
7	Reversible Bag Breaking Knife
8	Flanged Cone Bottom w/ Legs (optional)
9	HEPA Filter Element (optional)
10	Motor with Fan (optional)
11	On/Off Switch (optional)

THE DENSE FLOW BAG DUMP UNIT is used when manual, small bag emptying is necessary. Units come with an integral dust collection system, which can include HEPA filtering. Bag dumps are also available with dust tight door and arm length gloves, for a totally clean exterior atmosphere. Many custom configurations, such as round or square units, flanged cone bottoms & legs, can be designed and manufactured by J.D.B. DENSE FLOW INC.

NOTE: Specifications and dimensions subject to change.