

DENSE FLOW COMPACT BIN VENT

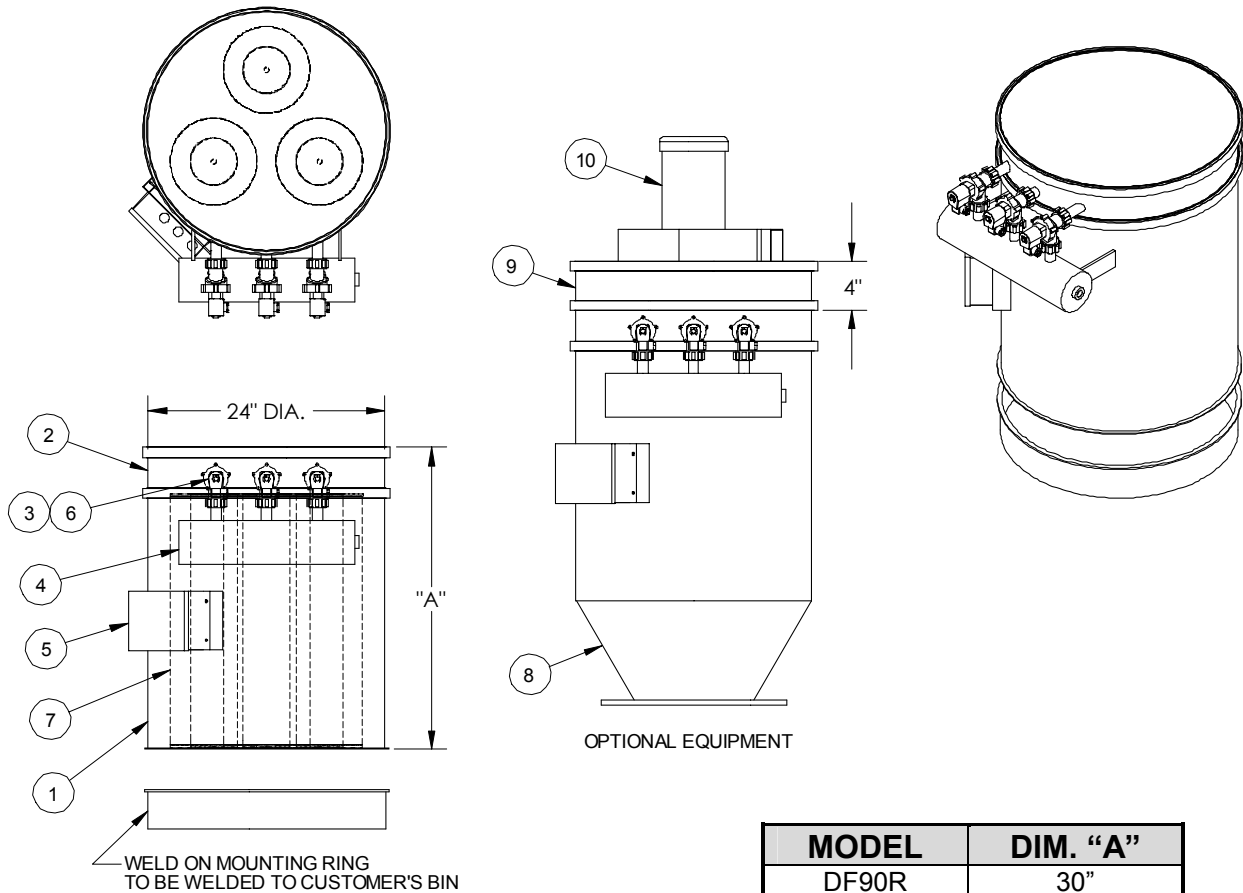

MODEL	DIM. "A"
DF90R	30"
DF110R	30"
DF160R	54"
DF210R	54"

ITEM	DESCRIPTION
1	Housing 12 GA.
2	Removable Clean Air Plenum
3	Diaphragm Valve
4	Compressed Air Header
5	Timer Control Panel
6	Solenoid Valve
7	Filter Cartridges
8	Flanged Cone Bottom (optional)
9	HEPA Filter Element (optional)
10	Motor with Fan (optional)

THE DENSE FLOW COMPACT BIN VENT is used for separating clean air from the dust-laden air of the conveying system. It's pulse jet design allows for efficient cleaning of the filter cartridges. The compact design allows for installation in tight areas. Many filter options are available; aside from our standard polyester felt cartridges, such as HEPA, PTFE and Paper. Many custom configurations of the Compact Bin Vent can be designed and manufactured by J.D.B. Dense Flow.

NOTE: Specifications and dimensions subject to change.